

**EXPANSION OF EPS CONSTRUCTION METHOD  
AND  
SOME CONTRIVANCE FOR APPLICATION OF ROCK FALL PREVENTION  
IN JAPAN**

Gosaburo Miki<sup>1</sup>, Shuichi Kuroda<sup>2</sup>, and Yoshihiro Sato<sup>3</sup>,

**Abstract**

Fifteen years have passed since EPS construction method was first introduced to Japan from Norway. The amount of EPS used in Japan has already exceeded 2.5 million m<sup>3</sup>. Its application can be found in an extremely wide range that includes the original prevention works of soft ground, reduction of earth pressure, space filler, buffer protection and many others. EPS construction method can, thus, be comprehended not only as a simple lightweight-embankment-construction method but also as a unique construction method making the best possible use of various characteristics of EPS. Today, EPS construction method is absorbed in Korea and Singapore in Asian countries, besides Japan, and it is expected to expand into Taiwan and China in the future.

In process of today's construction designs for EPS construction method, it is required to pay an attention to the creep characteristics of EPS. It is also expected to develop even better effective method for wall structure, which protects vertical face of EPS embankment.

The collapse of a huge rock mass, occurred in February 1996 at the entrance of Toyohama tunnel in Hokkaido Prefecture, has become a trigger and the application of EPS construction as protection of bedrock collapse and rock falls has rapidly increased. The thesis introduces some of representative EPS construction examples applied as protections for those occurrences. It also discusses the results of the experiments carried out to learn EPS rock fall shock-absorbing performance.

**Keywords;** EPS, Creep, Retaining wall, Rock fall, Lamé's constants, Attenuation of the earth

---

<sup>1</sup> Chairman, EPS Construction Method Development Organization, Chiba, Japan

<sup>2</sup> Co-manager, Construction Project Consultants, Inc., Osaka, Japan

<sup>3</sup> Secretary, EPS Construction Method Development Organization, Tokyo, Japan

## 1. Progress of EPS Construction Method in Japan

Expanded Poly-Styrol (EPS) construction method was first introduced in Japan in 1985. Its method has been studied and developed into many possibilities at EPS Construction Method Development Organization (referred to as EDO), which was founded in 1986, and today, it has established reliable fields of EPS as some methods of civil engineering. Its construction opportunities, as of the year-end 2000, count 4,335 cases with its total construction volume of 2566973 m<sup>3</sup>.

### (1) Construction Progress and EDO's History

EPS construction method was first introduced in Sapporo, Hokkaido Prefecture in August 1985. It was a remarkable first step made by the engineers of those days, who studied very hard to see a possibility of adapting the method in Japan based on the overseas technical papers. Table 1.1 shows a brief history of EDO.

Ever since EPS construction method was introduced to Japan, EDO has carried out a number of experiments and studies including open tests, as well as technical lectures in different cities. As for the aseismic performance of EPS fill that had been considered troublesome since its introduction, EDO first carried out some experiments using a shake-table. It recently performed an actual size of the eight-meter-high shake-table test, and judging from the excellent results obtained from those experiments and studies, it can be said that they proved superior aseismic performance of EPS fill.

Figure 1.1 shows progress of construction volumes since EPS construction method was first introduced to Japan. When EDO was established, it was right in the bubble economy in Japan in which every business was extremely prosperous. The domestic EPS consumption volume reached over 0.1 million m<sup>3</sup> per year in the fifth year of its establishment. The trend indicated as if to promise a continuous expansion of the Japanese economy in every three to four years, and despite a burst of the bubble economy as well as the worldwide recessions, EDO managed to perform a constant progress even in such a difficult period. Judging from such tendencies, the growth of EPS consumption volume can be divided into the beginning of '90s with 0.1 million m<sup>3</sup> per year, mid-'90s with 0.2 million m<sup>3</sup> per year and the end of '90s with 0.3 million m<sup>3</sup> per year. The accumulated construction volume exceeded over one million m<sup>3</sup> in 1995, and today, it reached 2.57 million m<sup>3</sup> per year.

### (2) EPS Adapted Fields in Japan

The use of EPS in Japan is summed up and shown in Figure 1.2. EPS is overwhelmingly used for roads in our country, followed by use for parks, grounds and every type of land developments marking at 12.6% and for constructions at 4.0%. It has never been used for railroads or airports. Secondly, Figure 1.3 shows its use forms. The most commonly used form of EPS is as an embankment for soft grounds and landslides in the hope of effecting load decrease by occupying 37 % of the total share. The share of use for widening road in the hope of EPS self-support is 21.8% while use for backsides of bridge abutments in the hope of reducing earth pressure is 19.5%.

Though small in volume, on the other hand, there are some constantly penetrating cases of EPS use as buffer for prevention of rock fall, level raising of embankments, amendment of buried pipe culvert, and space filling for a purpose of reducing construction dead load. Those uses of EPS are penetrating due to the regional characteristics, geographical and geological features of Japan. EPS use as a floating type structure, which can be recognized in Norway, USA and Australia, is hardly applied in Japan even today.

### (3) Problems with Development of EPS Construction Method in the Future

The Japanese Construction Industry, which has progressed admirably, is now facing a serious confusing time from 2001 along with the prolonged recession. Today, Japan is reconsidering public investments and has started to reduce costs in various elements. EPS construction method has given an expensive image in the industry. It is considered that an improvement of further cost reduction is necessary from now on. In the meantime, a new lightweight embankment construction method is making a steady progress. It is represented by the foam mixture of lightweight soil (such

as FCB construction method), which is produced by mixing cement and foam materials, and the urethane foam construction method that blends compounds, such as isocyanate. The latter method, in particular, is increasing its construction rate these days due to its excellent workability. The urethane construction method at this stage is considered to have some problems with earth environment, effects on human, animals and plants as well as underground water due to the use of chlorofluorocarbon and the harmful gas created when it forms. We are certain that EPS construction method is free of such problems like leakage of harmful substance, weather resistance and durability, since the method uses EPS blocks produced completely in factories.

On the other hand, by judging from the development in Asian countries, experiments of EPS applications in Singapore, Taiwan and Sri Lanka are active in the last few years. Furthermore, it is organized to run a seminar on the Japanese EPS civil engineering fields in China in this autumn at a convention of their EPS industry. There is no doubt that China with its huge land is the largest commercial country even in the general economy. It is expected that an unprecedented construction volume to be realized in China even with EPS construction method in the future. It is quite interesting to observe a unique and new development of EPS in China with different from the existing EPS method.

## **2. Reconsideration of Detailed Structures of EPS Fill**

Currently EDO is proceeding a development in collaboration with Hokkaido Civil Engineering Research Institute in regard of a new wall structure for widening road fills. Geographically our country is complicated and steep, and more roads are connected in mountain areas in today's road maintenance works. Here, the problems of EPS fills with their designs and constructions that have been reconsidered, now and then, are discussed.

### **(1) Creep Settlement of High Embankments**

EPS fills will be compressed and deformed elastically depending on their dead load and vertical load from the upper force. Deformation volume can be calculated by the elastic coefficient of EPS. The calculations and the observed figures from constructions show almost identical results. When the ground that supports EPS fills is soft, there will be some compression sink during construction of EPS filling. A problem, here, is a creep deformation within EPS blocks. Due to expansion of EPS construction method and conditions of road locations, even higher and larger scale of EPS filling is demanded.

The highest EPS filling ever carried out today in our country is 18 meters. Special attention must be paid in case of creep deformation of EPS blocks when a height of embankment exceeds over ten meters. Figure 2.1 shows indoor observation examples of creep deformations. When a load exceeds a certain level, a sample material starts to make creep deformation. Deformation of about 0.5% of the top part of embankments can be found even in the actual construction sights. EDO has only those two data today, and the indoor data of Figure 2.1, in particular, lacks in data of both possible reemergence and long-term observation. It is believed that causes for creep deformation on construction sights are due a height of embankment and the time spent for its construction. The sights where creep deformations have been observed notably are the spots where rapid constructions have been carried out for the purposes of natural disaster relief and reduced construction terms. During the process, from filling EPS to constructing railings along roads and paving, none of these cases had been given a rest, and on the contrary, they had been hurried to finish the works. As post treatments of creep deformation, measures such as to repair road railings by adding extra height to complete it with the same height as the original plan for a road surface are obliged (see Figure 2.2). When there is any misgiving about a creep deformation at the stage of designing, the similar repair will be premised on. If not, it will be necessary to take some measures like using rigid blocks or reinforce blocks by pouring mortar into provided holes in the blocks. We need in the future to gather information on field observations of high embankments as well as various indoor experimental studies.

## **(2) New Wall Structure**

Today's most common wall structures, to protect EPS vertical fill surface in Japan, are as shown in Figure 2.3. They have structures that joined walls with H-steel and the lightweight hollow concrete slabs with bolts. EPS and the H-steel are joined with anchor bars, which are buried into concrete slabs that are provided in every three meters height. Those structures allow the H-steel and the anchor bars to make an up-and-down movement so that they can cope with vertical deformation of EPS fills. From the collaboration study, EDO and Hokkaido Development of Public Works Research Institute concluded that, so long as EPS fills and the backside ground are bound with ground anchors, there would be no serious damages with stability of such constructions, happenings like projections of EPS blocks, fallings and sliding of embankments themselves. Retaining walls also must be able to protect styrol from catching fire and melting, as well as deterioration by ultraviolet rays. In our country, the ratio of retaining walls in the total EPS filling construction cost occupies more than 30 percent. Further development of effective retaining walls is required for deformation mode of EPS fill, which can cope with situations more flexibly and prevent from burning and deterioration by ultraviolet rays.

## **3. Rock Fall Prevention by EPS Construction Method**

In February 1996, a huge rock mass, whose volume was over 11,000 m<sup>3</sup>, collapsed by smashing Toyohama Tunnel located along the national road 229 in Hokkaido. The rock mass was 100 meters above the entrance of the tunnel, and a school bus on the way to school was passing through the tunnel when the accident occurred. By ill fortune, the collapse of the rock mass took away over twenty of invaluable lives in a flash.

With this disaster as a momentum, inspections of prevention against disasters were executed simultaneously throughout the country, and every kind of prevention works, including rock fall prevention was proceeded. As multiple construction methods, such as materials of space filler and buffer protections of rock shed, and temporal embankment for removing rock mass, EPS construction method has began to be used rapidly from that time.

### **(1) Examples of Rock Fall Prevention by Using EPS Construction Method**

The cases by applying EPS shock absorbing prevention are indicated in Figure 3.1-3.4. The most commonly used rock fall prevention construction is shown in Figure 3.1. With the construction, EPS blocks are placed along the side where there is any fear for rock falls, so as to improve efficiency of its shock absorbing. Figure 3.2 shows a study case to protect a large section of a tunnel, designed eight meters underground from the surface with filling soil from a huge rock mass located over 70 meters above the ground. The study proved that there was excessively excavated soil surrounding, and thus, this construction work was not realized. The construction in Figure 3.3 is to reduce strain of concrete by improving shock absorbing efficiency with EPS fills on the existing rock shed. Figure 3.4 also shows EPS fills that were constructed for the purpose of temporal embankment for the designed removal of rock mass to protect the existing tunnel structure from the rock mass located above the tunnel. As Figure 3.5 shows, it is an important data that succeeded to remove the rock mass under the traffic control by blasting at its feet and to make it tumble down on the EPS slide as designed so.

Outline of those designs is as follows:

- 1/ The design in Figure 3.1 was that those who managed roads stocked EPS blocks as materials for prevention of disasters and placed them in the areas where were in danger of rock falls. It is considered that the design was based on experiences.
- 2/ An experiment design in Figure 3.2 was executed by both Japan Road Corporation and EDO for a purpose of inspecting the spots concerned. It was studied from results of the analysis which will be explained later.
- 3/ The design in Figure 3.3 can be divided broadly into two categories. One is to lead from experiment formulas by calculating an intrusion force that accompanies with a rock fall impact

force and a thickness of EPS establishment. The other design is developed by Hokkaido Development Bureau. It is to measure buffer protection and stress variance with the three-layered structure of EPS, soil and steel plates. Please refer to the thesis by Mr.Konno for the details.

**(2) Experiments of Rock Fall Shock Absorbing Protection**

1) Outline of Experiments

The experiments were carried out as described below in the rented land in a suburb of Mobara City, Chiba Prefecture. In Japan guidelines for mechanisms of rock falls and prevention methods are described in a Handbook for Rock Fall Prevention (referred to as Handbook). As for rock fall impact force, its estimation can be calculated by Formula 3.1. In this formula, however, a conduct of Lamé’s constants takes a great part in a standard of prevention works. The Handbook is described in vague expressions, and thus some attentions must be paid for certain applications of each buffer material. The experiments were carried out to study to what extent of Lamé’s constants would be indicated by materials among shock absorbing materials, that include EPS.

$$P_{max} = 2.455W^{2/3} \lambda^{2/5} H^{3/5} \dots\dots\dots \text{Formula 3.1}$$

W: rock mass weight (t)

H: rock fall height (m)

$\lambda$  : Lamé’s constants (t/m<sup>2</sup>)

Very soft: 1000kN/m<sup>2</sup>

Soft: 3000~5000kN/m<sup>2</sup>

Solid: 10000kN/m<sup>2</sup>

Results of the ground experiments that were carried out previously are shown in Figure 3.6, and the arrangement plans of the experiments are charted in Figure 3.7, and Table 3.1.

2) Experiment Results

The experiment results are put in order in relations between the rock fall heights and the largest impact forces. They are shown in Figure 3.8. The repeated data are converted into Lamé’s constants and shown in Table 3.2. Correspondent to rock fall frequencies, there were dispersions in the experiment data, but when either soil or EPS was applied, a value  $\lambda=100$  was proved to be appropriate. When concrete was used, it resulted with much larger figure of  $19 \times 10^3$  tf/m<sup>2</sup> than the one indicated in the Handbook ( $1 \times 10^3$  tf/m<sup>2</sup>).

As for transmission of impact force in depth of the underground, on the other hand, one of the cases is shown in Figure 3.9. The figures indicate difference in attenuation of the earth with a case without shock absorbing materials and a case with EPS. When EPS is used as buffer material, it can be easily understood that impact force itself eases when falling. It is also recognized that even attenuation of the earth with EPS, shows better effect on attenuation and alleviation.

3) Conclusion

As for rock fall shock absorption, various studies are carried out in respective institute in Japan. It is true that along with types of countermeasures, their solutions also vary. The related experimental results are summarized as below.

\*It is judged that Lamé’s constants for a calculation of shock absorption, when EPS and soil are used as shock-absorbing materials, 100 would be reasonable.

Shock absorbing effect with thickness of EPS is also recognized.

\*Even for the attenuation of the earth, both shock-absorption and attenuation effects are recognized when EPS is used as shock-absorbing material. It is also considered to be effective as a shock-absorbing method for underground constructions.

**(3) Problems to Be Solved for Rock Fall Prevention Using EPS Construction Method**

Application of EPS construction method for rock fall prevention and some of sample designs in Japan have briefly been described here. Previously stated simultaneous inspections and preparation availed general rock fall prevention throughout Japan, but having the limited budget, it is believed that close observations are still required to establish essential solutions corresponding to each geographical and geological structure and characteristics of figure of rock mass. On the other hand, some problems are also left with EPS design method for rock fall prevention.

- 1/ the optimum response efficiency of EPS against strong impact force
- 2/ an adaptability of application of styrol waste material

- 3/ an adaptability of EPS recycle
- 4/ compound with soft urethane

Problem 1/ can be presented only for rock falls whose response characteristics are relatively small at the current stage, and for the larger scale rock mass falls and high impact forces that are as large phenomena as a collapse and degradation, individual experiment and analysis are required. The experiment with EPS shows the maximum of weight limit is about three tons. It is necessary to make more realistic evidences for constructions like Toyohama's class.

Problem 2/ is an adaptability of styrol waste discharged from every type of industries and smashed into fine pieces. When it is very hard to predict a time of occurrence of rock fall, an application that matches costs and effects is considered to be more required in the future. For example, in addition to today's countermeasures of reuse of the smashed and melted wastes, we need to work out a possibility of adopting bagged waste pieces as buffer protection material, as well as EPS recycle materials with which the demand is increasing earth-wise as mentioned in Problem3/. As for Problem 4/, the use of soft urethane produced in factories is considered to be the unknown area to mix scrap caused at a stage of processing and the application mentioned in Problem 2/.

#### **4. Conclusion**

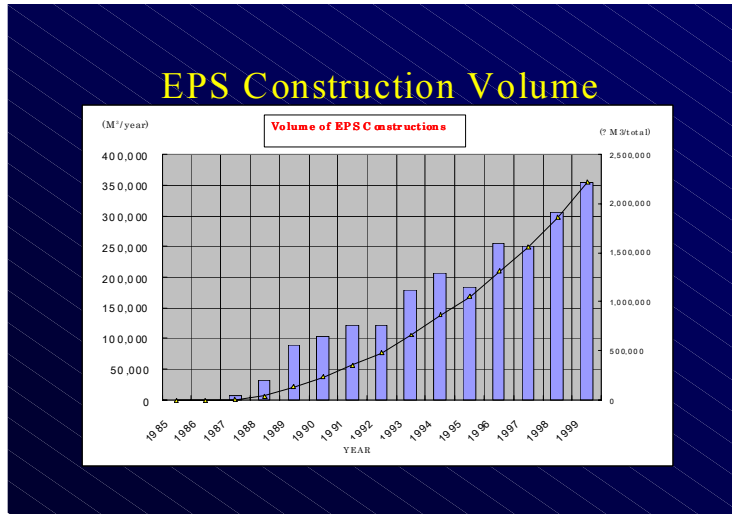
The progress and the current situation of EPS construction method in Japan, the problems we need to reexamine in details of designs, and EPS construction method for rock fall prevention have been discussed here. As for EPS construction method, ever since its development in Norway, a steady study has been proceeded, and we have been able to make various effective results, including aseismic performance in this seismic country, Japan. The most blessed environment for the people involved with EPS is a network that connects Europe, America and Asia. Some of the problems mentioned here should be recognized, not only as the problems in Japan but also as the common problems of the related people of the world. I, therefore, anticipate that we exchange information and make efforts to find solutions for those problems from the world.

#### **References**

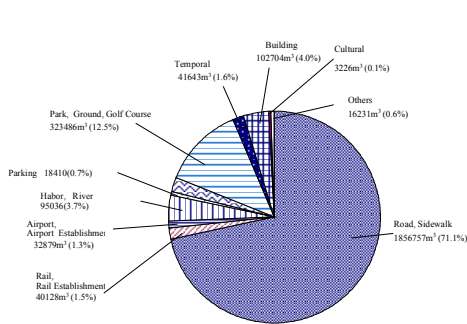
- 1)RikohTosyo; EPS Construction Method, Aug1988.
- 2)Extec; Rock Fall Prevention in KIRIGATAKI of 2<sup>nd</sup> Meishin Expressway, March2000.
- 3)Miyoshi Tatsuo; A Report of Restoration to Deal with Natural Calamities in KATANAGAKE, The 37<sup>th</sup> Technical Conference of Hokkaido Civil Engineering Research Institute,1993
- 4)Yoshihiro Sato; The Field Experiment of a Method for Rock Fall Shock Absorbing, Proceeding of the 35<sup>th</sup> Japan National Conference of Geotechnical Engineering, June2000.
- 5)Japan Road Association, A Handbook for Rock Fall and Prevention, June 2000.

**TABLE- 1.1 A Brief History of EPS Construction Method Development Organization**

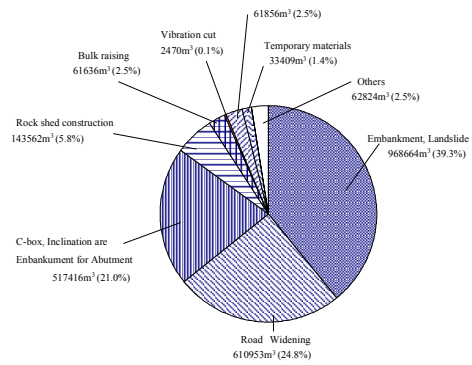
Year	EDO's brief history	Detail of other countries
1866		Styrene monomer compound method was found in Germany
1972		EPS construction method, which was developed by Norway National Road Institute, was first applied for embankment of abutment construction near Oslo.
		The method is adapted for embankment of backside of abutment in Michigan, America.
1985	The Japanese embankment construction for attachment of abutment in Inazumi Park, Sapporo City.	Oslo International Conference
1986	*Establishment of Development Organization *It took a part in a collaboration work of "A basic construction method for buried pipe culvert" with Japan Housing and City Improvement Corporation. *Examination of "widening retaining wall construction" in Nakatsukawa City. *Numazu bypass construction work for No.1 National Road.	
1987	*The actual size test by Public Works Research Institute of Ministry of Construction. *Static and dynamic studies on EPS commenced at universities and institutes.	
1988	*"Studies on static and dynamic stability of styrofoam block aggregate" by Product Technical Institute of Tokyo University. *"Research on an inequality subsidence construction method for sewer pipes" by Housing and City Improvement Corporation. *"20Hz2million times shake test" by Railway General Technical Institute.	
1989	*"Retaining wall earth pressure test" by Public Works Research Institutes of Ministry of Construction.	
1990	*"Shake-table tests on aseismic efficiency of EPS fill and other related tests" by Public Works Research Institute of Ministry of Construction. *"Studies on application of styrofoam for railroad embankment" by Railway General Technical Institute. *Technical exchange seminar with Mr.Tor Erik Frydenlund from Norway Road Institute.	
1991	*Dynamic deformation tests for evaluation of aseismic efficiency. *Soil microorganisms and mold resistance tests for evaluation of weather resistance. *FWD tests for evaluation of EPS roadbed (carried out with No.1 National Road of Ministry of Construction)	
1992	*FWD tests for evaluation of EPS roadbed (carried out with No.9 National Road of Ministry of Construction)	
1993	*Damage investigation of earthquake occurred off Kushiro and Noto Peninsula. *Temporal road load tests of Gassan Dam.	
1994	*"Dynamic repetition load tests of EPS material" by Railway General Technical Institute.	*North America Geo Technical Symposium (at Hawaii University) *Korea EPS International Conference *The 5 <sup>th</sup> International Geo Textile Meeting
1995	*Damage investigation of Hyogo-ken-Nanbu earthquake.	*Korea National Road Technical Study (in Pusan). *BROMS Symposium (in Singapore)
1996	EPS TOKYO '96	
1997	*"Actual size shake-table tests of double vertical wall type EPS fill" by Development Organization	
1999	*Inspection of H&C block construction method.	
2000	*"Collaboration study on retaining wall structure for widening embankment" with Hokkaido Development Bureau, Development of Public Works Research Institute. *Damage investigation of the west of Tottori, Geiyo earthquake.	*Taiwan light embankment study (Taiwan Science Technology University) *Holland CROW EPS Symposium.



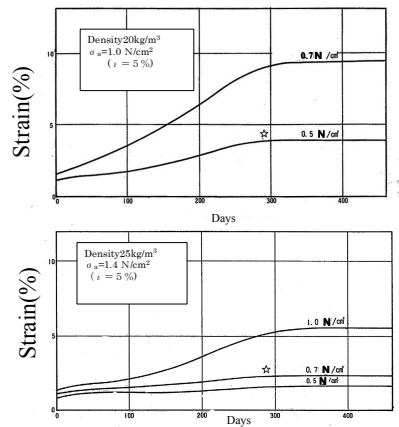
**Fig.1.1** EPS Construction Volume in Japan



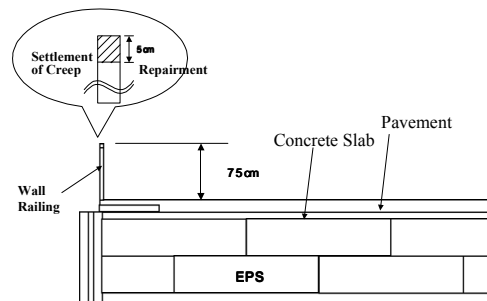
**Fig. 1.2** Use of EPS in Japan (Construction Volume / m<sup>3</sup>)



**Fig. 1.3** Shape of EPS in Japan (Construction Volume / m<sup>3</sup>)

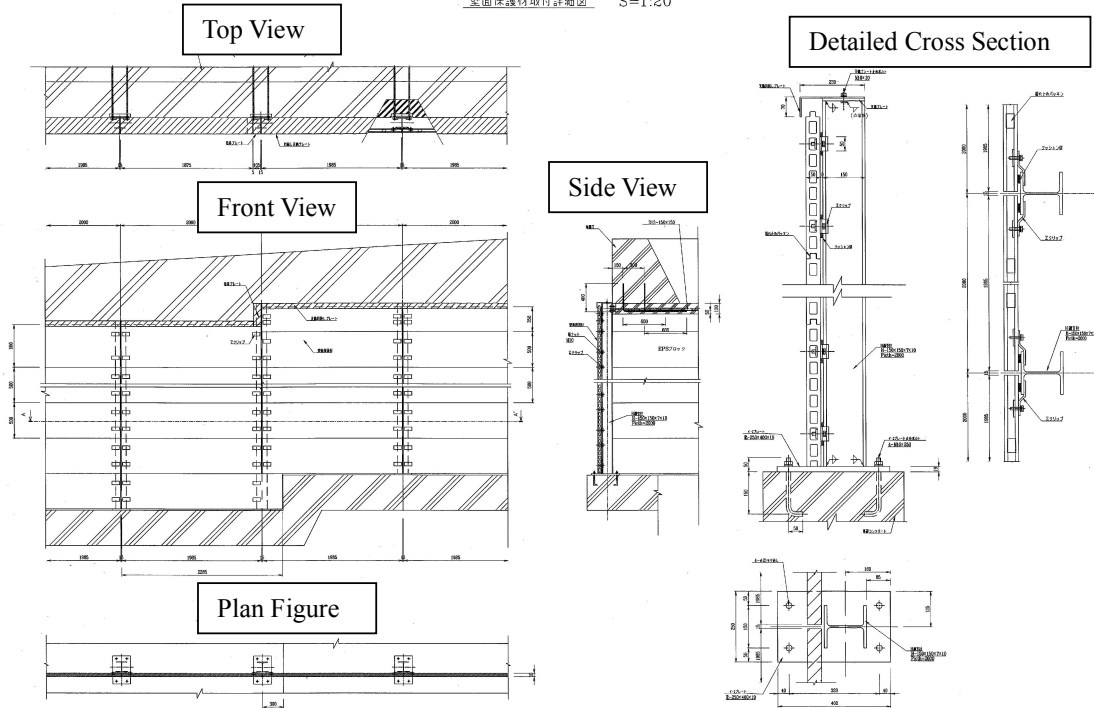


**Fig.2.1** Characteristic of EPS Compressed Creep

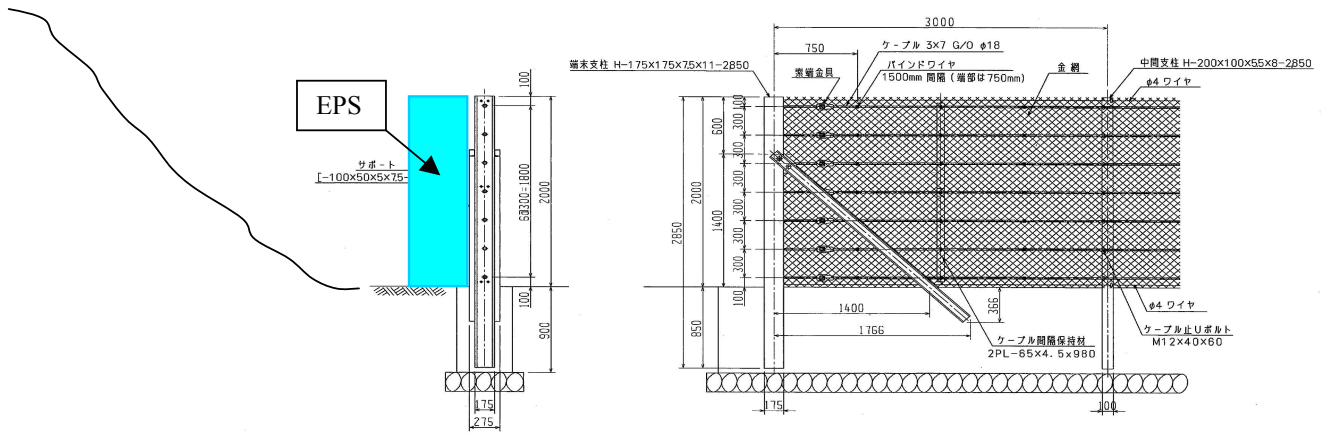


**Fig. 2.2** Subsidence Repairment Example of Wall Railing





**Fig-2.3 Standard Wall Structure of EPS Fill in Japan**



**Fig-3.1 General Rock Fall Retaining Wall Construction and Use of EPS**

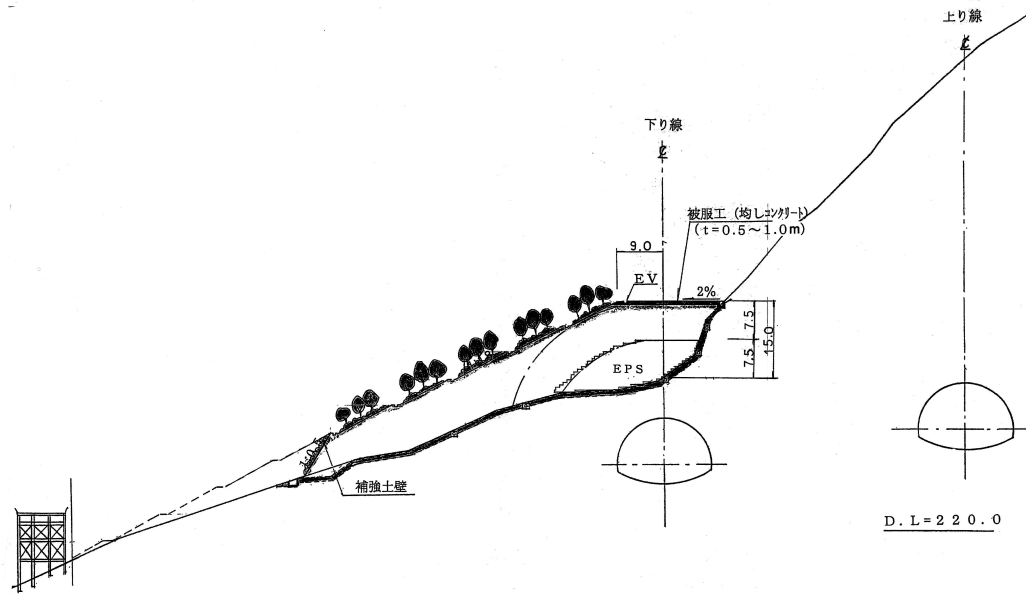


Fig-3.2 Investigation of Rock Fall Shock Absorbing Prevention by EPS

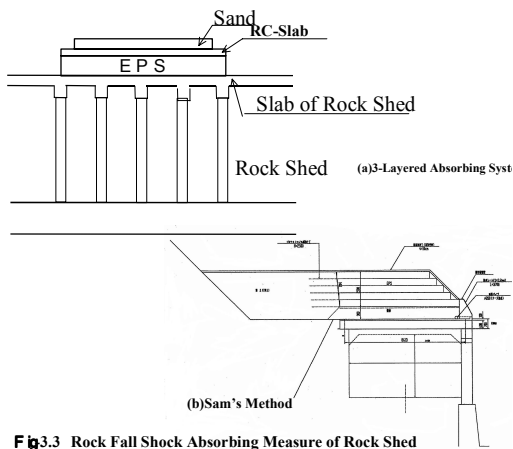


Fig 3.3 Rock Fall Shock Absorbing Measure of Rock Shed

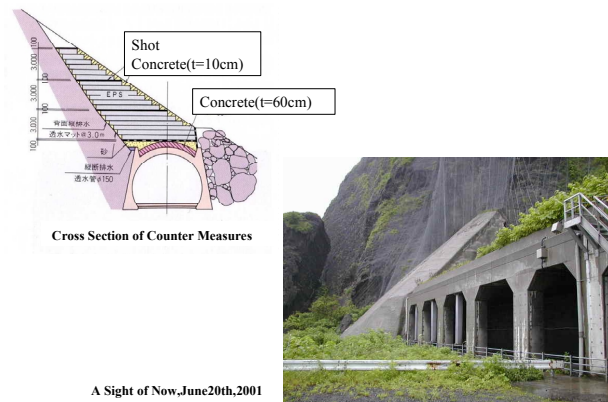


Fig-3.4 EPS Temporal Embankment Used for Removing a Rock Mass

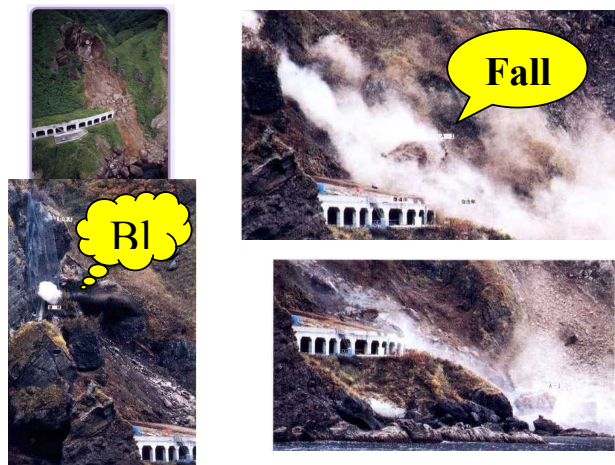


Fig-3.5 EPS Temporal Embankment Used for Removing a Rock Mass

nature of soil	Humus soil	Soil mixed with grain of sand
sample number	3 - 1	3 - 2
gathered sample depth (g on 3)	1.50m ~ 1.70m	5.80m ~ 6.20m
density of grained soil (g on 3)	2.251	2.659
moisture content (%)	125.5	25.7
pebble portion (%)	-	0
soil portion (%)	-	87
silt portion (%)	-	10
clay (portion %)	-	3
parity factor	-	2.91
curvature factor	-	1.45
largest diameter of granule (mm)	-	0.850
liquid limit (%)	163.6	NP
paste limit (%)	48.6	NP
plasticity index	115.0	NP
ignition loss test L i (%)	14.9	-

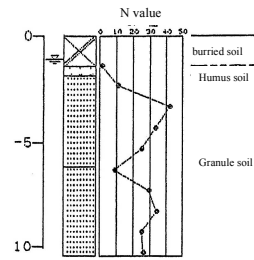


Fig-3.6 Result of Ground Inspection  
at Rock Fill Experiment Sight

Table-3.1 outline of Rock Fill Experiments

item	内容	備考
weight	base 36×36cm height 94cm steel rectangular mass 0.8t	
ground condition	buried soil · humus soil · sand ground	execution of soil analysis and standard intrusion tests
height of fall	5 · 10 · 20 meters of vertical free fall	
buffer materia	EPS, soil, concrete, natural, ground	
measuring equipment set up	equip an acceleration meter as a weight and bury it into the 4th degree in depth	

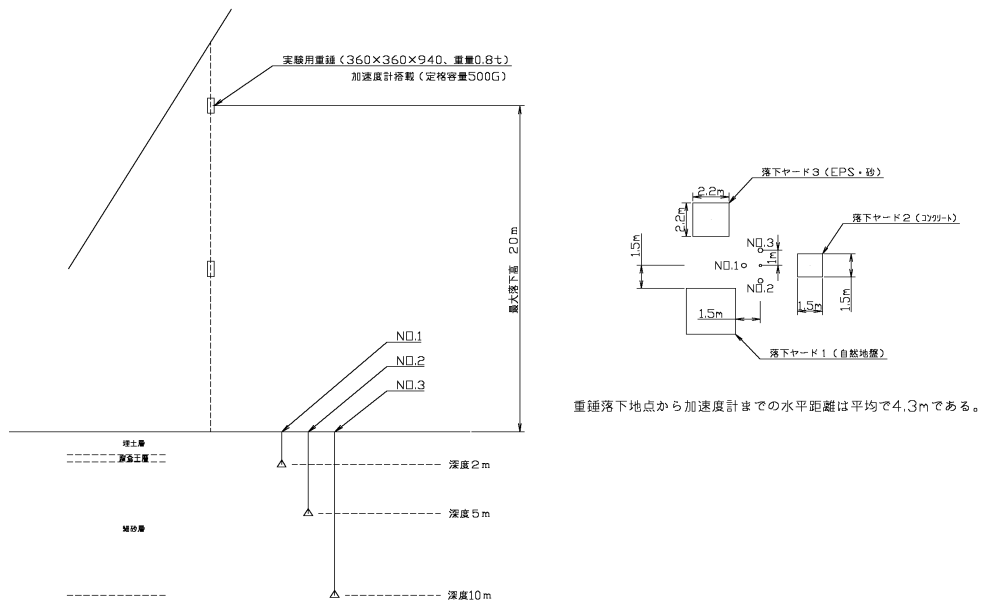


Fig-3.7 Brief Chart of Rock Fall Experiment

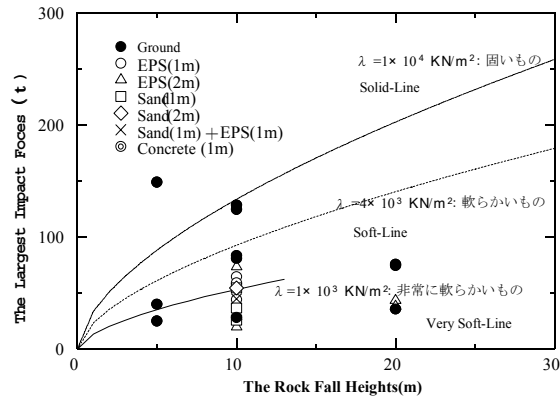


Fig-3.8 Relation Between Rock Fall Height and Conversion Impact Force

Table-3.2 Lamé's Constants for Ground(Shock Absorbing Materials)

	Impact Force (tf)	Apparent Lamé's constants (KN/m <sup>2</sup> )
Natural Ground	104.3	$5.4 \times 10^3$
Concrete	440.5	$2.0 \times 10^5$
EPS (1 m)	56.0	$1.1 \times 10^3$
EPS (2 m)	40.7	$0.5 \times 10^3$
Sand (1 m)	38.9	$0.5 \times 10^3$
Sand (2 m)	54.4	$1.0 \times 10^3$
Sand+EPS	44.8	$0.7 \times 10^3$

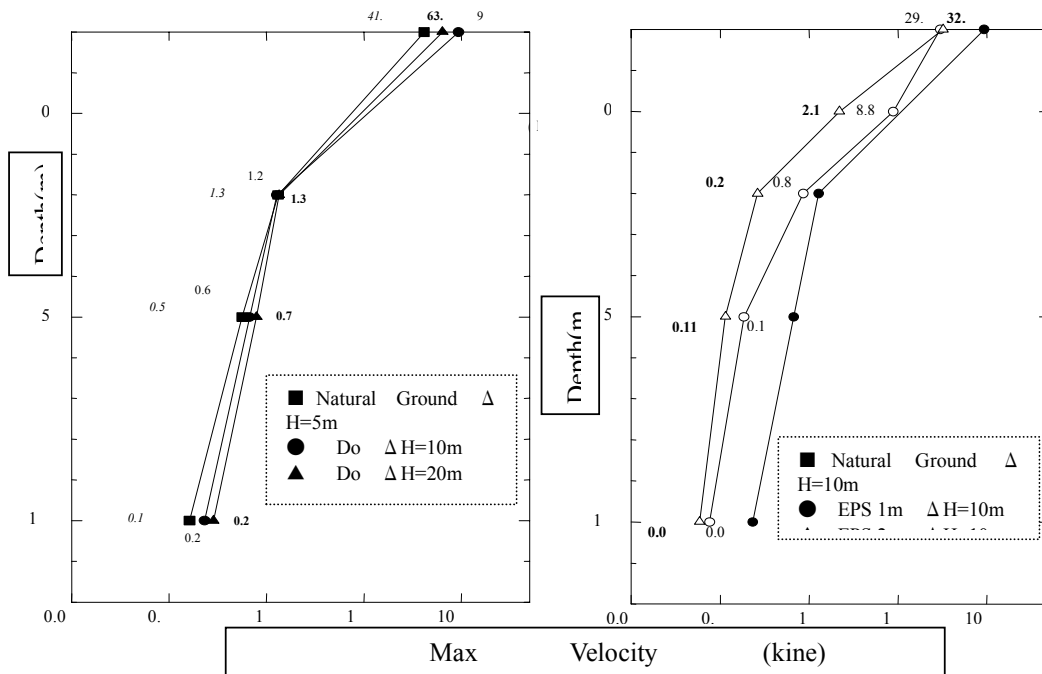


Fig-3.9 Characteristics of Attenuation of Earth